

IP Security Camera User Manual



IPCAMHD62

For video setup guide and FAQs - Go to www.serenelifehome.com

Product Structure Diagram

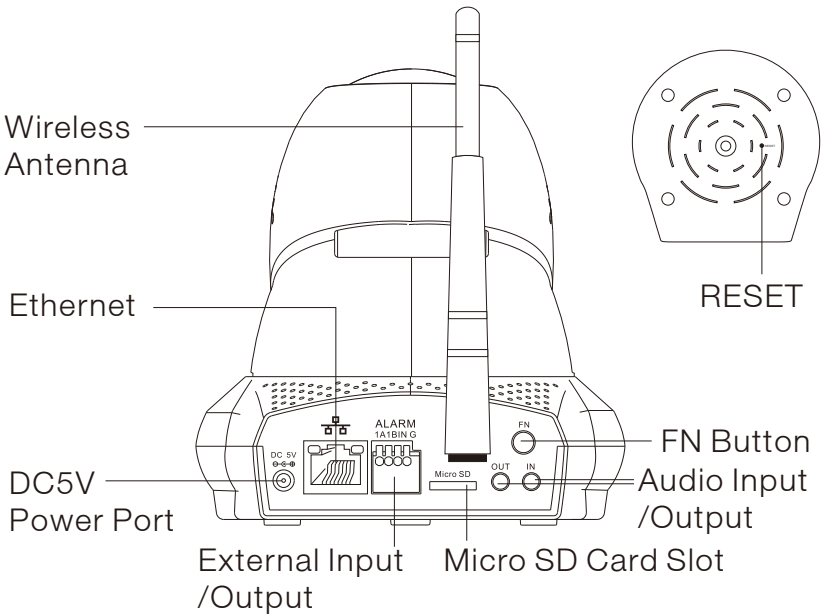
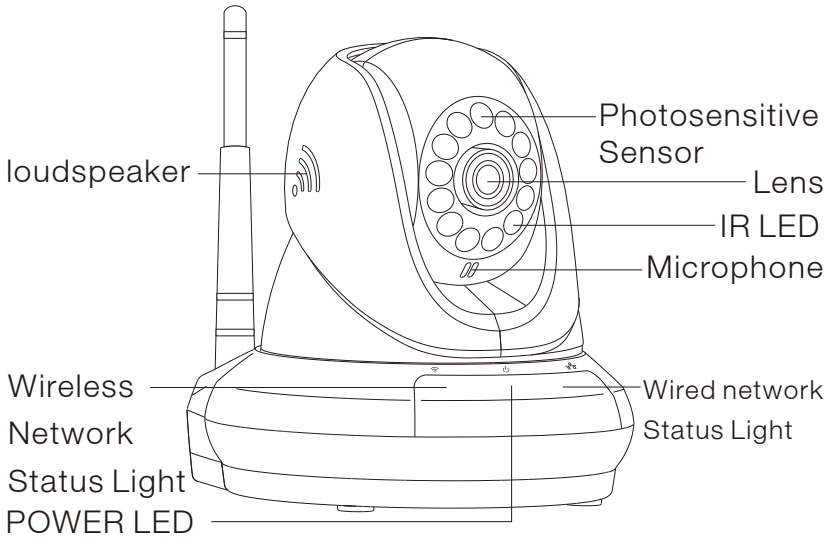

Note: FN button has no function at this time

Don't forget to register your camera with us online to get a free 1 year manufacturer's warranty!

Just go to www.SereneLifeHome.com

'SereneViewer' APP Installation

A. Scan 'SereneViewer' APP QR code or search to download the app.



iOS



Andriod

Setup an Account Username

Click "Sign Up"



Create your camera username
-6 characters min
-Do not use email address

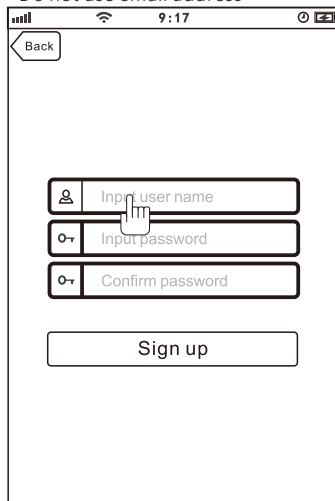

Note: This user name will be used to access all of your cameras from the app or PC.

Create an account password - Click "Sign Up"

Note: This will be used to log in to all of the cameras on your account and can be separate from the camera password

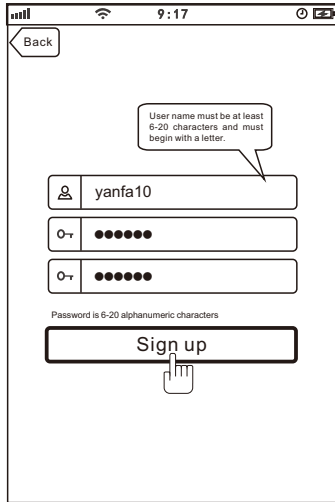

Add Camera to APP

1. Enter 'Device List' and click '+' icon at the top of left corner. Then scan the device ID QR code.

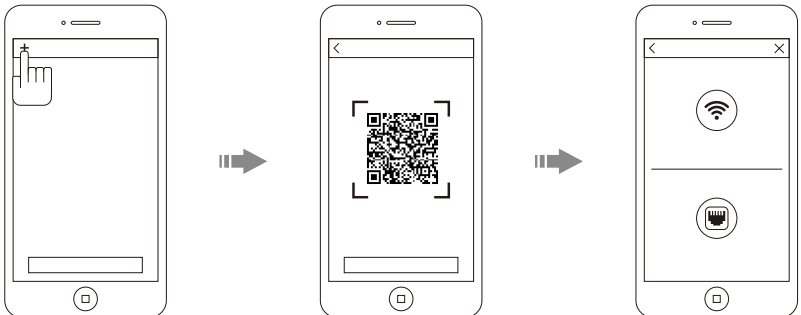

Connect to Your Network

Choose method 1 or 2 for setup

Method 1: Wired Setup

- Connect power, Ethernet cable and the wireless antenna as above.
- Wait 50 seconds for (📶) indicator on the camera to **flash green**
- After scanning QR code - select the "Ethernet Connection" option

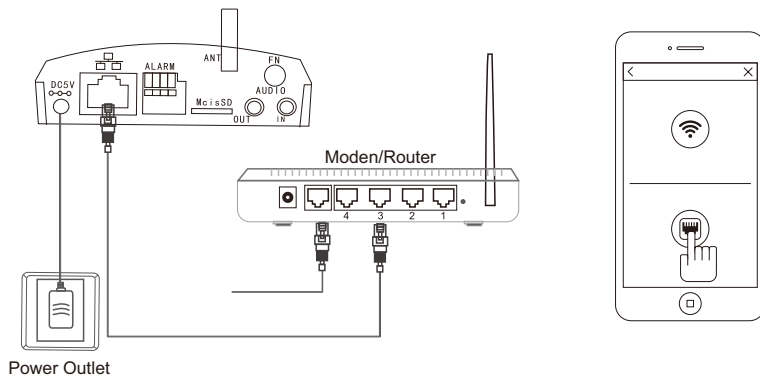

Method 2: Wi-Fi connection

- Make sure you are in the same room as your wireless router and plug camera into power
- Wait 1-2 min for camera boot up, watch for the WiFi indicator on the front of the camera to flash green and red alternating.
- If WiFi only flashes red - perform a hardware reset to change the camera back to Wireless setup mode. If still only red follow "Method 1 Wired Setup"

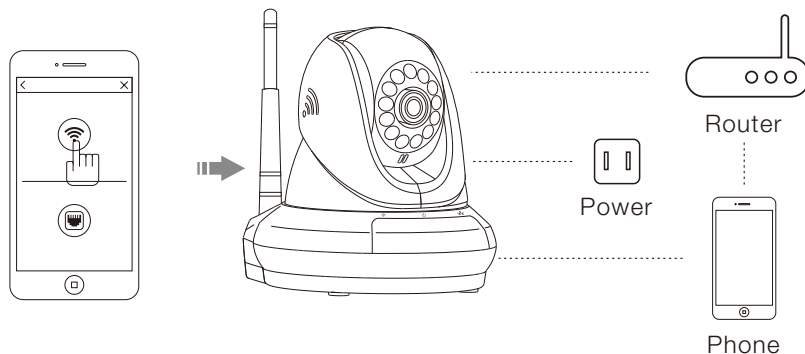

Web Access:

After setting up your camera on the mobile phone - you can use your account username and password to access the cameras from any device with an internet browser

Log on to the website:

<http://cloud.serenelifehome.com/>

Passwords

Should you happen to forget a camera's individual password you can reset it by performing a hardware reset. Just use a pin to press and hold the reset switch for 12 - 15 seconds. The camera will reboot and run through pan and tilt.

If you forget your account password you will need to register a new account and pair the cameras again.

Accounts are never associated with an email address for password recovery

Mobile App Layout

The main screen is your device list.

You will see a thumbnail preview for all cameras added to your account.

Use this menu to

- Switch between different cameras
- Add new devices
- Access and change app global settings

Add device

Add your cloud camera to your account through the icon.

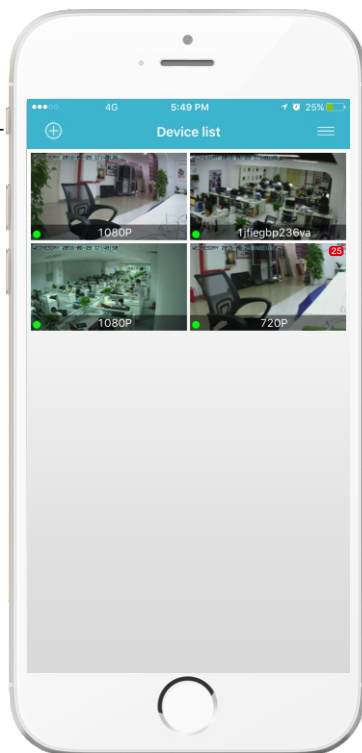

App settings

You can change your user admin and guest password and check the app software version.

Alarm messages

Shows which cameras have detected motion.

Camera View Page

This page give you access to all camera specific actions and settings

- Hold the phone vertically or horizontally to switch between full screen mode
- Swipe left and right on the video to reposition the camera
- Spread two fingers apart to zoom in

Sound

Activate to hear your cameras surroundings

Microphone

Activate to talk through your camera's speaker.

Snap photo

Saves a photo to your phone's local memory

View the video records and alarm messages

Click the icon to view the video recording and alarm message.

Image Settings

Set color, contrast, image res and more.

Local video

Records the live video direct to phone memory. This feature only works while app is open. See "SD recording" for background recording options.

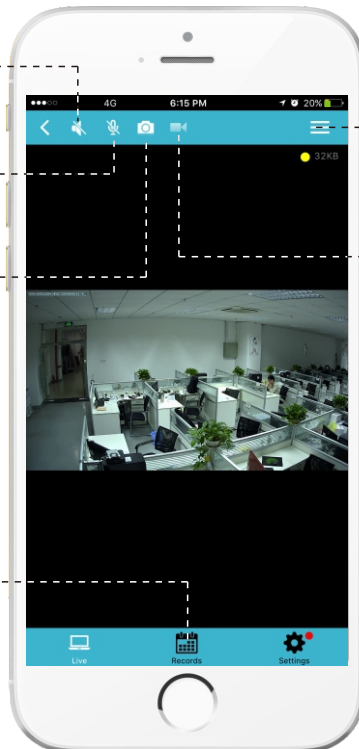

Camera Recordings

Enter into the interface of “information and video viewing” can see the alarm information and video of storage device(Micro SD or cloud box), users can quickly search the information and video by choose the time or category.



Records

Shows photos and videos stored on the SD memory card
Drag the screen down to load.

Local

Shows photos and videos recorded to the phone memory

Calendar Icon

Skip to a specific date and time..

Device settings

This screen allows you to check and set camera specific settings.

If you see the red dot icon - a firmware update is available. Install available firmware updates to ensure the camera features are working as intended.

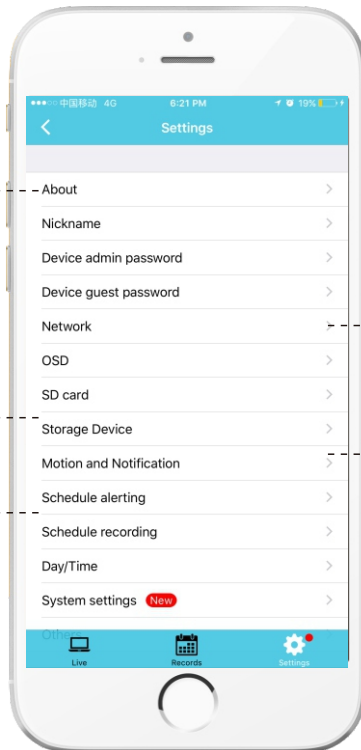

About

Check the camera's software version and ID number.

Storage Device

Connecting Cloud Box for storage

Schedule recording

Set the recording schedule start and end time.

Network

Can set up the camera Wi-Fi connection

Motion and Notification

Set the motion detection alarm.

Recording Your Camera

You can choose 3 options for storing recordings for your camera

1) Local storage

This is the most simple method - just point and shoot. This only works while the phone app is open and running and will take up memory on your phone.

2) SD storage

Install an SD card and open up a world of possibilities!

Choose between scheduled recording, motion detection triggered recording or just let it run! The oldest videos will be overwritten to make room for the newest. You can download and save the videos from the mobile or website.

3) CloudBox storage

Sometimes SD storage just doesn't cut it. With a limit of 32g and the fact that the videos are stored directly in the camera - many people prefer the peace of mind the CloudBox can bring. Purchase the cloud box and back up 2TB of video storage from any device on a single network and check the videos from the same login. Find the CloudBox for sale on Amazon now! Search "SereneLife CloudBox"

SD Recording

Note: Make sure you have a class 10 SD Micro Card 32G or less. Format must be FAT32.

- 1) Insert SD Card into your camera
- 2) Go to > camera settings > SD Card in the mobile app
- 3) Slide to Enable the SD card
- 4) Click "Format" to Erase any card data - wait for the camera to reboot

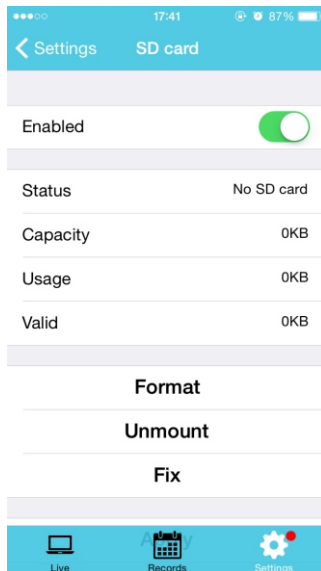

Note: If the card capacity does not show data after reboot. Power down your camera and plug back into power while the SD card is already inside the camera.

Next you can choose your record trigger preferences between

A) 24/7 recording - camera always records

B) Scheduled recording - camera records during specified time frame

C) Motion detection recording - camera only records when motion is detected

To enable option A or B - Go to the camera settings and select "Schedule Recording"

Here you can enable 24 hour mode or set specific time frames during which the camera will record.



To set up "Motion Detection Recording - Go to the camera settings
> "Motion Detection"

Once enabled, you can select to trigger camera recording and image snapshots

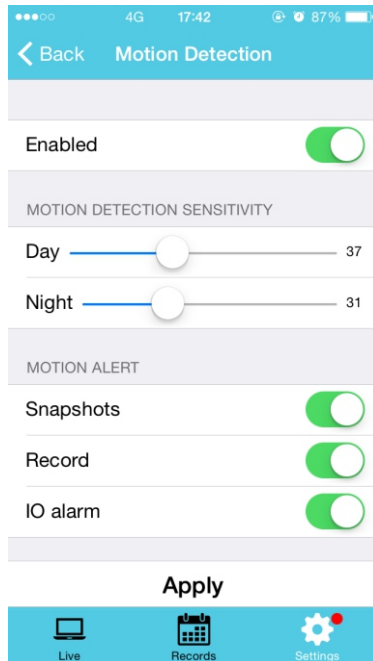

You can also change the "Pre-record length" which will add "X" number of seconds before the motion was detected to the video file saved.

Motion Detection and Notifications

You can set notification settings separately for any camera in your account.

To access the notification settings, select your camera, and go to the settings tap - then scroll down to "motion detection"



Slide the slider to enable motion detection

You can then choose what actions you would like to occur when your camera detects motion.

-I/O alarm will send a signal to any equipment you have attached to the camera I/O output ports

-Snap Shot will record a still image to the SD card in your camera

-Record will record video to the SD card while the camera detects motion.

-You can also turn push notifications on and off by selecting "turn alert on" or "turn alert off"

If you are finding your camera is alerting you needlessly or failing to alert you if someone is moving, you can adjust the sensitivity for motion detection for the camera.

Troubleshooting

Can't connect to WiFi

- Connect the ethernet cable and check connection is working
- Go to “camera settings” > “network” Check the WiFi status is enabled and “List” displays your home network - doublecheck the password.
- In the Ethernet tab - disable the ethernet connection to force the camera to look for available WiFi network

Still having trouble?

- Try deleting the camera entry from your account
- Hardware rest the camera
- Add the camera as a new device

SD Card is not recognized by the camera

- Check the card is class 10 - 32g or less
- Insert the card while the camera is powered down then power up
- Try reformatting the card using your computer using “FAT32”
- Test multiple SD cards

App is crashing - a feature is not working

- Check for app updates
- Check for camera firmware updates
- Contact support with app version, mobile device model and OS version so we can update the app and fix the issue

Other issues? Check our FAQ resources and contact support online!

www.SereneLifeHome.com

Troubleshooting Weak Network

There are a lot of different variables in your home network that may affect wireless performance including available bandwidth, camera placement, data demands of the camera, and interference.

You can use free online tools to help measure your network performance and identify opportunities for improvement.

If you are having trouble with your camera connection - first you will want to check if it is a problem with wireless access - wired or both.

1) Run a speed test online from a laptop or desktop connected to your router with a wired connection

<http://www.speedtest.net/>

2) Now unplug your laptop and run the test again while connected to WiFi.

You can move about your home to see if the location you are planning to install the camera has a strong wireless signal

-What is your download speed in the same room as your wireless router?

-What is the download speed in the location you are trying to install the camera? Is there a significant drop?

If your wired connection is too slow to reach the bandwidth requirements of the camera you may need to consider upgrading your internet service.

If you have a significant drop in data when testing a wireless connection in the same room as your router, you may want to consider upgrading to a router that can provide higher data transmission speeds

If you see a significant drop in data when testing in the area you want to install your camera you can either look for an upgraded router that will offer additional range or you can expand your router range with a signal booster.

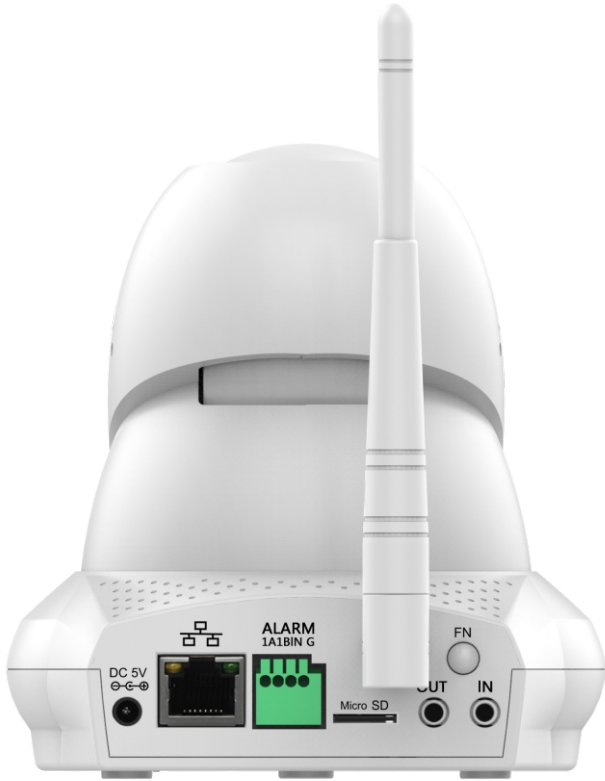

Don't miss out!

Free 1 year Warranty

Find the product registration form on our website www.SereneLifeHome.com