

Visit Our Website



SCAN ME
PyleUSA.com

Dynamic Microphone Kit

USER GUIDE

PYLE

PyleUSA.com

Features:

- Includes (3) Handheld Microphones & (3) XLR Audio Cables
- Built-in Acoustic Pop Filters
- Ultra-Wide Frequency Response
- High Signal Output for Vocals & Singing
- Rugged Construction & Steel Mesh Grill
- Reinforced Sound Cartridge
- ON/OFF Switch for Stage Control
- Perfect for Stage Performances or In-Studio Use



Technical Specs:

- Mic Element: Hyper-Cardioid
- Pickup Pattern: Unidirectional Moving Coil
- Mic Construction Material: Zinc Alloy
- Audio Cable Connectors: XLR to 1/4"
- XLR Cable Length: 26'+ Ft.
- Open Circuit Sensitivity: -54 dB
- Frequency Response: 60Hz-15kHz
- Output Impedance: 600 Ohm, +/-3dB (0dB=1V/Pa @ 1kHz)
- Mic Dimensions (L x W): 6.7" x 1.8" (-Each)
- Mic Weight: 0.61 lbs. (-Each)

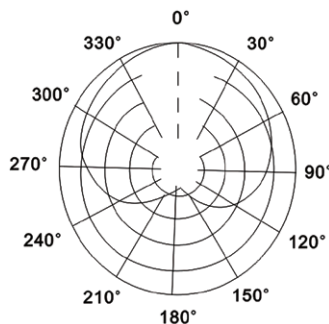
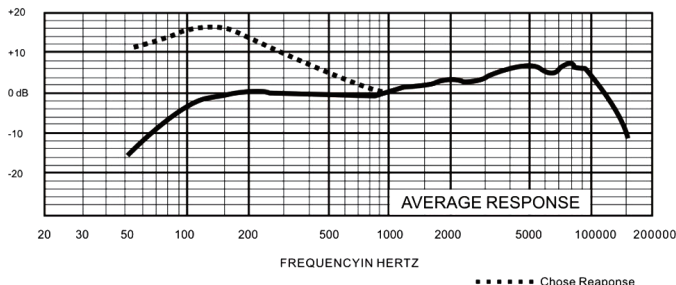

Cardioid (at 1KHz)

WARNING: Cancer and Reproductive Harm - www.P65warnings.ca.gov

Connecting and Disconnecting the Microphone Cable

- 1. Connecting the Cable:** Insert the XLR connector into the microphone. If necessary, rotate the connector to align the key on the connector with the groove in the microphone. Push the connector into the microphone until it clicks, indicating a secure connection.
- 2. Disconnecting the Cable:** To disconnect the cable from the microphone, grasp the connector while depressing the tab. Gently pull the connector away from the microphone to release it.

Usage Guidelines

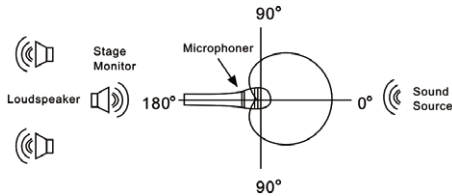

- 1. Optimal Placement:** For the best gain-before-feedback and isolation from undesired background noise, aim the microphone toward the sound source and away from unwanted sound sources.



- 2. Handling the Microphone:** Do not cover any part of the grille with your hand. Covering the grille alters the sound and distorts the polar pattern, increasing the chance of feedback.

Cautions

- 1. Feedback Prevention:** If the head of the microphone is covered by your hand or brought close to the speaker, a howling sound may be generated. To prevent this, first decrease the volume, then position the microphone so that it is not pointed towards the speaker and there is sufficient distance between the microphone and the speaker.
- 2. Maintenance of the Grille and Windscreen:** It is important to keep foreign particles out of the grille and the windscreen as they may alter the frequency response of the microphone. Clean the grille periodically using warm, soapy water. Rinse with plain water and let it dry completely before replacing.
- 3. Handling the Microphone:** Due to the high sensitivity of the cartridge, avoid dropping it from a height or applying strong shocks to it.
- 4. Environmental Conditions:** To maintain the sensitivity and quality of sound reproduction, avoid exposing the microphone to moisture and extreme temperatures.



Questions or Comments?
We are here to help!
Phone: 1.718.535.1800
PyleUSA.com/ContactUs